

**ESTIMATION FORM**

V.3.0

**REPAIRER DETAILS**

COMPANY NAME	
COMPANY ADDRESS	
CONTACT PERSON NAME	
DESIGNATION	
TEL :	
FAX :	
EMAIL :	

**CLAIM TYPE**

TICK ONE ✓

1	OWN DAMAGE (OD)	
2	WINDSCREEN	
3	OD-THEFT RECOVERY	
4	OD-ACTUAL TOTAL LOSS	
5	OD-BEYOND ECONOMICAL REPAIR (BER)	
6	OD-CONTRACT REPAIR	
7	OD-KFK	
8	THEFT	
9	THIRD PARTY PROPERTY DAMAGE (TPPD)	
10	THIRD PARTY BODILY INJURY (TPBI)	

**ACCIDENT INFORMATION**

**DAMAGE CATEGORY**

TICK ONE ✓

1	ACTUAL TOTAL LOSS (ATL)	
2	BEYOND ECONOMICAL REPAIR (BER)	
3	CONTRACT REPAIR	
4	REPAIRABLE DAMAGES	
5	CASH-IN-LIEU	
ACCIDENT DATE ( dd/mm/yyyy )		
LOCATION OF DAMAGED VEHICLE		
VEHICLE TOWED TO WORKSHOP		Yes No
DRIVEABLE?	Yes No	3RD PARTY INVOLVED? Yes No



**ACCIDENT INFORMATION**

POLICE REPORT NUMBER	REPORT DATE
POLICE STATION STATE	POLICE STATION ID NUMBER
INVESTIGATION OFFICER (IO) NAME	IO ID NUMBER

**INSURANCE INFORMATION**

INSURANCE COMPANY NAME			
POLICY NUMBER			
COVERAGE PERIOD			
START DATE ( d/m/y )		END DATE ( d/m/y )	
SUM INSURED ( RM )		MARKET VALUE ( RM )	
WINDSCREEN COVERAGE	Yes	No	AMOUNT COVERED ( RM )

**OWNER / DRIVER INFORMATION**

NAME			
ADDRESS			
POSTCODE	CITY	STATE	
COUNTRY			
MOBILE NUMBER	HOME PHONE	OFFICE TEL NO	OFFICE FAX NO
EMAIL			
GENDER		DOB ( dd/mm/yy )	
DRIVING LICENSE NO			
START DATE ( dd/mm/yy )		EXPIRY DATE ( dd/mm/yy )	
LICENSE CLASS			

**ACCIDENT CIRCUMSTANCES AND VEHICLE OCCUPANCY**

Vehicle Occupancy :

Accident Circumstances :

Is the Vehicle Immobilised as a Result of the Damage Sustained?

Yes / No

Prior to the Accident, was the Vehicle Safe & Legal to Drive?

Yes / No

Is the damage sustained by the vehicle consistent with the circumstances provided?

Yes / No

**VEHICLE APPRAISAL ON CONDITION NOTES**

**ADDITIONAL INFORMATION / CANDIDATE NOTES**

VEHICLE DATA																
MAKE				MODEL				TRIM LEVEL				ENGINE SIZE				
GEARBOX				FUEL TYPE				REGISTRATION NUMBER				DERIVATIVE				
Manual	Automatic	Petrol	Diesel	LPG	Hybrid											
PAINT								VEHICLE IDENTIFICATION NUMBER ( VIN )								
Solid COB		Metallic COB		Pearl COB												
BODY SHAPE								AUDIO UNIT ( MODEL REF. )				ODOMETER READING				
Saloon	Hatch	Estate	Conv.	Coupe	MPV	LCV	Pickup									
								NO. OF DOORS		2	3	4	5	6		

EQUIPMENT / OPTIONS FITTED																							
AIRBAGS														SEAT BELT									
Front		Knee		Front (seat/door)		Rear (seat/door)		Anti Submarine		Curtain		Rear head		Pre tensioners									
Driver	Pass.	Driver	Driver	Pass.	L/hand	R/hand	Driver	Pass.	L/hand	R/hand	Fitted	Deployed	Driver	Pass.									
Fitted	Deployed	Fitted	Deployed	Fitted	Deployed	Fitted	Deployed	Fitted	Deployed	Fitted	Deployed	Fitted	Deployed	Depl.	Depl.								
													LH	Centre	RH								
													Depl.	Depl.	Depl.								
Air Con.		Alloy Rim		ABS / ESC		Cruise		ADAS		S/roof		GPS		LED Day Light		FR Parking Sensor		Reverse Sensors		Tinted		Alarm/Immob.	

CONDITION & OPERATION															
STATIC TEST						WARNING LAMPS ILLUMINATED						COLOUR CODED			
Foot Brake		Steering		Parking Brake		SRS	ESC	ABS	Engine Mngt.	Coolant	Other	Bump.	Mould.	Mirror.	Handl.
Pass	Fail	Pass	Fail	Pass	Fail										

Mark direction of impact on diagram

Seat Frame - FR LH	
Seat Frame - RR LH	
Seat Frame - RR Centre	

Seat Frame - FR RH	
Seat Frame - RR RH	

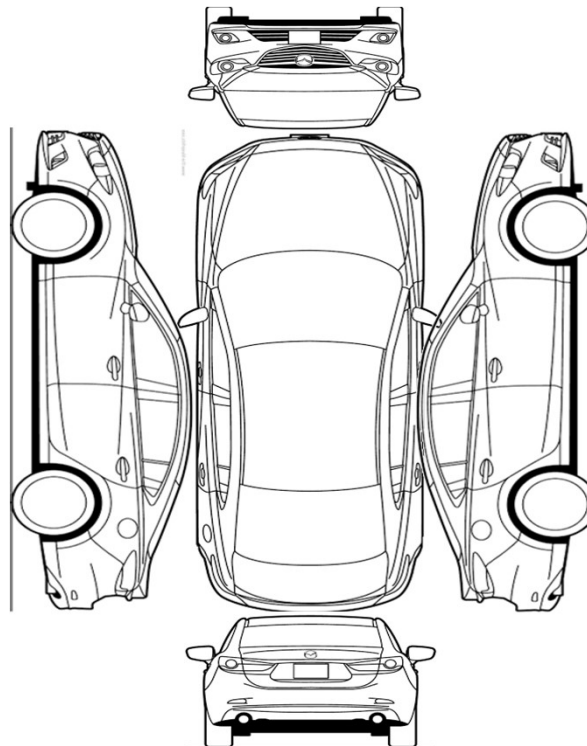

Tyre - FR LH	
mm	
Size	
Brand	

Tyre - FR RH	
mm	
Size	
Brand	

Tyre - RR LH	
mm	
Size	
Brand	

Tyre - RR RH	
mm	
Size	
Brand	

Tyre - Spare	
mm	
Size	
Brand	

Condition	Very Good / Good / Fair / Poor
-----------	--------------------------------







